

M]a i hYf]Y

H3D-M MULTI-FUNCTION ANALOGUE TIMER



CHARACTERISTICS :

- Wide operating voltage range, AC/DC 12V~240V
- 7 output modes :
On-delay
Control contact OFF-delay
Interval
Trailing edge interval
Flasher starting with ON
Flasher starting with OFF
Single shot
- 7 time range, from 1 second to 100 hour
- 17.5 mm thin body design
- CE certified

SPECIFICATION :

Operating voltage	AC/DC(V): 12~240
Allowable operating voltage range	90~110% of rated operating voltage
Rated frequency	50 / 60 Hz
Contact rating	250VAC 8A (resistive load)
Reset time	MAX 0.1s
Power consumption	Approx. 1.9VA
Life	Mechanical: 5,000,000 times Electrical: 100,000 times
Ambient temperature	-10 ~ +50°C
Ambient humidity	MAX 85%RH
Weight	Approximatly 62g

TYPE SELECTION :

Type	H3D-M
Time range	1s / 10s / 100s / 10m / 100m / 10h / 100h
Output contact	1C
Output mode	7 Mode

CONNECTION :

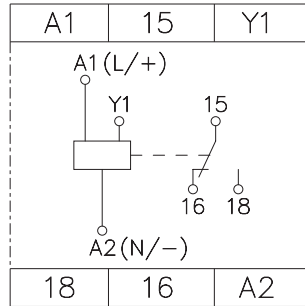

TIMING CHART :

Mode A: On-delay,

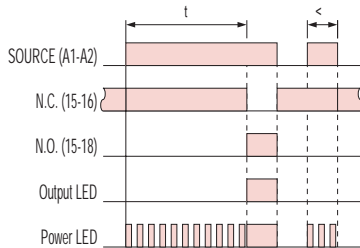

Mode B: Flasher starting with OFF,

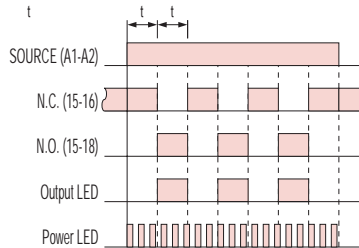

Mode B2: Flasher starting with ON,

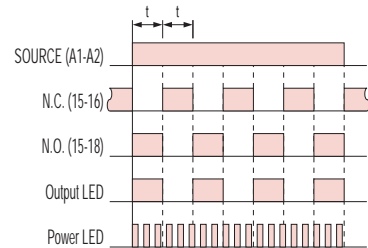

Mode D: Control contact OFF-delay,

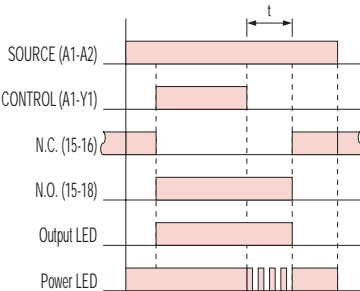

Mode D1: Trailing edge interval,

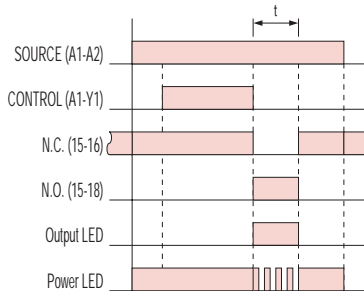

Mode E: Interval,

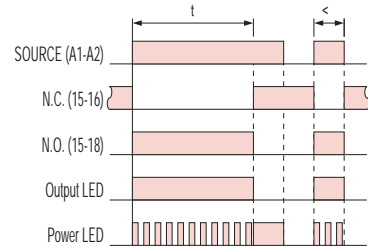

DIMENSIONS : (mm)

Mode J1: Single shot,

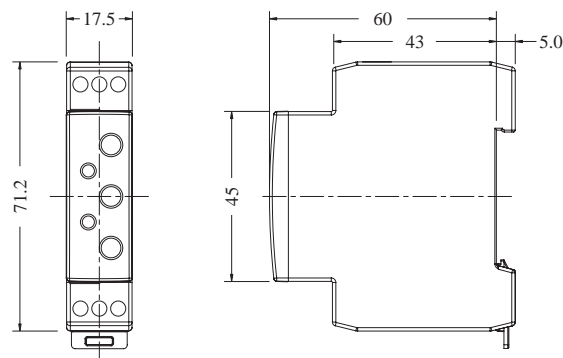
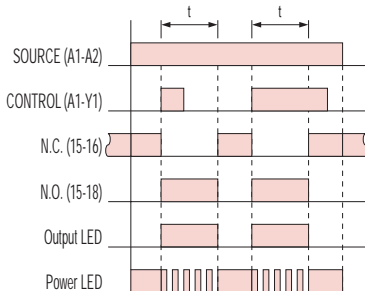

GSD automatisme
3 Rue Louis Ganne

75020 PARIS

Tel: 01.40.31.22.22 / Fax: 01.40.31.22.44

www.gsd-automatisme.com

info@gsd-automatisme.com