

Sensors without integrated amplifier | STA 421 K-HB2

- G1/2 screw-in sensor for flow monitoring in liquid media
- Corrosion-proof housing made of Hastelloy B-2
- Immersion depth 31 mm
- 2 m fixed cable FEP
- Installation in T-piece connector or welding sleeve
- Needs amplifier with analogue or switching output

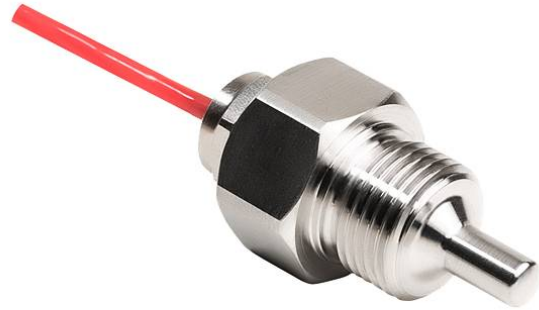

G1/2 hastelloy B2 - sensor length 31 mm - FEP-cable

TYPE	STA 421 K-HB2
Product ID	P10625
Medium	Water, oil
Detection range water	1 ... 150 cm/s
Detection range Oil	3 ... 300 cm/s
Process connection	G1/2
Sensor length L	31 mm
Ambient temperature	-20 ... 80 °C
Medium temperature	-20 ... 80 °C
Temperature gradient fluids	250 K/min
Start-up time typ.	8 s (2 ... 15 s)
Reaction time typ.	2 s (1 ... 13 s)
Compressive strength	100 bar
Material sensor touched by medium	Hastelloy B-2
Material housing	Hastelloy B-2
Protection [EN 60529]	IP 68
Electrical connection	2 m FEP-cable 4x0.25 mm ²
Accessories (in scope of delivery)	2 x gasket G1/2 AFM 34
Associated amplifiers	SKM 420, SKM 522, SKZ 400

Note

probe with longer cable available on request, temperature range 10 °C...120 °C on request

Technical Image

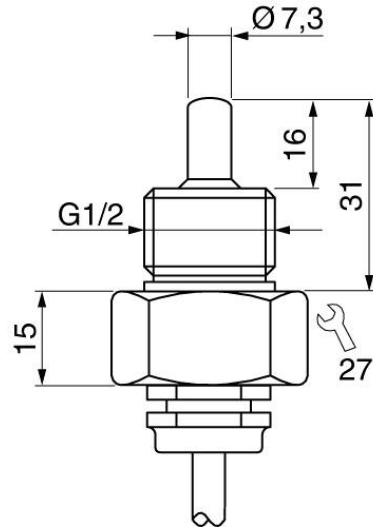

Pin Map

