

Sensors without integrated amplifier | ST 421 S-L120

- G1/2 screw-in sensor for flow monitoring in liquid media
- Corrosion-proof stainless steel housing AISI 316 Ti
- Immersion depth 120 mm
- M12 plug system
- Installation in welding sleeve
- Needs amplifier with analogue or switching output



G1/2 - sensor length 120 mm - M12 connector

TYPE	ST 421 S-L120
Product ID	P10905
Medium	Water, oil
Detection range water	1 ... 150 cm/s
Detection range Oil	3 ... 300 cm/s
Process connection	G1/2
Sensor length L	120 mm
Ambient temperature	-20 ... 80 °C
Medium temperature	-20 ... 80 °C
Temperature gradient fluids	250 K/min
Start-up time typ.	8 s (2 ... 15 s)
Reaction time typ.	2 s (1 ... 13 s)
Compressive strength	100 bar
Material sensor touched by medium	stainless steel AISI 316 Ti
Material housing	stainless steel AISI 316 Ti
Protection [EN 60529]	IP 67
Electrical connection	M12 connector
Accessories	connecting cable SLW 4-2 (Z00446), connecting cable SLG 4-2 (Z00445)
Accessories (in scope of delivery)	2 x gasket G1/2 AFM 34

Associated amplifiers

SKM 420 GR, SKM 420 GSP, SKM 420 GA, SKM 522 GR, SKM 522 WR, SKZ 400 GR, SKZ 400 WR-115, SKZ 400 WR

Technical Image

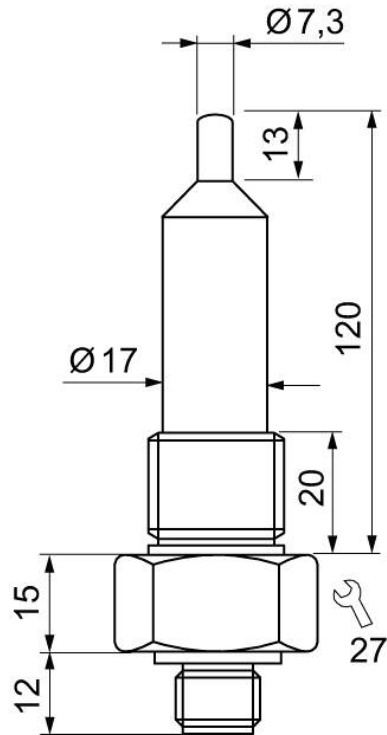

Pin Map

Messfühler Probe	3 BU	8	SKZ 400
	1 BN	7	
	2 WH	6	
	4 BK	5	

Messfühler Probe	4 BK	4	SKM 420
	3 BU	3	
	2 WH	2	
	1 BN	1	

Messfühler Probe	4 BK	4	SKM 522
	3 BU	3	
	2 WH	2	
	1 BN	1	