

## Sensors for explosive areas without amplifier for liquid media | ST 103 S

- G1/2 screw-in sensor for flow monitoring in liquid media
- ATEX approval for operation in Zone 1 and Zone 21
- Medium temperature up to 85°C
- Corrosion-proof stainless steel housing AISI 316 Ti
- Immersion depth 48 mm
- M12 plug system
- Installation in T-piece or welding sleeve
- Needs ATEX certified amplifier with analogue or switching output



### G1/2 - sensor length 48 mm - Ex-Zone 1/21 - M12 connector

<b>TYPE</b>	ST 103 S
<b>Product ID</b>	P11172
<b>Medium</b>	Water, oil
<b>Detection range water</b>	1 ... 100 cm/s
<b>Detection range Oil</b>	3 ... 200 cm/s
<b>Process connection</b>	G1/2
<b>Sensor length L</b>	48 mm
<b>Output</b>	output with separate Amplifier
<b>Ex area of use</b>	Zone 1, Zone 21
<b>ATEX Certificate</b>	TÜV 97 ATEX 1218
<b>ATEX marking gas</b>	Ex II 2 G Ex ib IIC T6...T3 Gb
<b>ATEX Marking dust</b>	Ex II 2 D Ex ib IIIC T125°C Db
<b>Maximum values</b>	$U_i = 13.65 \text{ V} / I_i = 200 \text{ mA} / P_i = 0.69 \text{ W} / C_i = 0.45 \text{ nF} / L_i = 1.80 \text{ } \mu\text{H}$
<b>Temperature range in T6</b>	-20 ... 40 °C
<b>Temperature range in T5</b>	-20 ... 55 °C
<b>Temperature range in T4</b>	-20 ... 85 °C
<b>Temperature range in T3</b>	-20 ... 85 °C
<b>Temperature range dust-Ex</b>	-20 ... 85 °C
<b>Start-up time typ.</b>	8 s (2 ... 18 s)

<b>Reaction time typ.</b>	2 s (1 ... 13 s)
<b>Compressive strength</b>	60 bar
<b>Material sensor touched by medium</b>	stainless steel AISI 316 Ti
<b>Material housing</b>	stainless steel AISI 316 Ti, brass, PA
<b>Protection [EN 60529]</b>	IP 67
<b>Electrical connection</b>	M12 connector
<b>Accessories (in scope of delivery)</b>	2 x gasket G1/2 AFM 34
<b>Associated amplifiers</b>	SZAb 400 EX-GR, SZAb 400 EX-WR115, SZAb 400 EX-WR230, SZAb 400 EX-GA

Technical Image

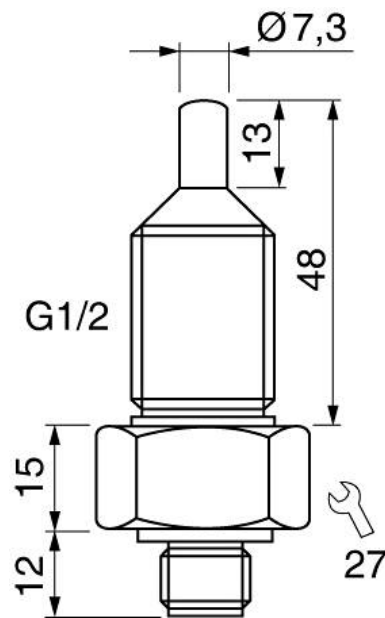

Pin Map

