

Sensors without integrated amplifier | ST 418 KH-A4

- M18x1.5 screw-in sensor for flow monitoring in liquid media
- Medium temperature up to 120 °C
- Corrosion-proof stainless steel housing AISI 316 Ti
- Immersion depth 47 mm
- 2 m fixed cable FEP
- Installation in compression fitting
- Needs amplifier with analogue or switching output



M18x1,5 - sensor length 47 mm - medium temperature up to

TYPE	ST 418 KH-A4
Product ID	P11356
Medium	Water, oil
Detection range water	1 ... 150 cm/s
Detection range Oil	3 ... 300 cm/s
Process connection	M18x1,5
Sensor length L	47 mm
Ambient temperature	10 ... 120 °C
Medium temperature	10 ... 120 °C
Temperature gradient fluids	250 K/min
Start-up time typ.	8 s (2 ... 15 s)
Reaction time typ.	2 s (1 ... 13 s)
Compressive strength	100 bar
Material sensor touched by medium	stainless steel AISI 316 Ti
Material housing	stainless steel AISI 316 Ti
Protection [EN 60529]	IP 68
Electrical connection	2 m FEP-cable 4x0.25 mm ²
Accessories	adapter SDA-SCS-G1/4 (Z01200), adapter SDA-SCS-G1/2 (Z01201), adapter SDA-SCS-G1/2-37 (Z01208)

Associated amplifiers

SKM 420 GR, SKM 420 GSP, SKM 420 GA, SKM 522 GR, SKM 522 WR, SKZ 400 GR, SKZ 400 WR-115, SKZ 400 WR

Note

with longer cable available on request

Technical Image

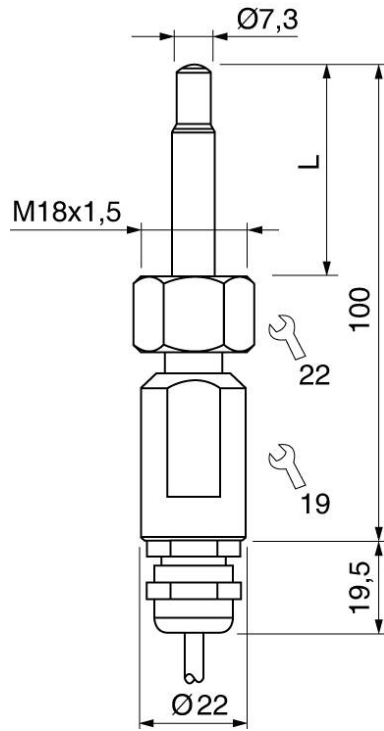

Pin Map

Messfühler Probe	3 BU	8	SKZ 400
	1 BN	7	
	2 WH	6	
	4 BK	5	

Messfühler Probe	4 BK	4	SKM 420
	3 BU	3	
	2 WH	2	
	1 BN	1	

Messfühler Probe	4 BK	4	SKM 522
	3 BU	3	
	2 WH	2	
	1 BN	1	