

Air flow sensors with integrated amplifier |

LG 518 GPL

- For air flow monitoring
- Screw-in or plugin installation
- Air flow monitoring in exhaust systems
- Flow monitoring for fans
- Filter state monitoring
- Sensors with io-link available



TYPE	LG 518 GPL
Product ID	P11431
Medium	air
Detection range air	0.5 ... 15 m/s
Detection range °C	-20 ... 70 °C
Process connection	M18x1
Output	IO-Link
[IOPDLSS]	0...1000 [% x 0.1]
Process data temperature	-200...700 [°C x 0,1]
Switching current max.	200 mA
Ambient temperature	-20 ... 70 °C
Start-up time	20 ... 40 s
Material sensor touched by medium	BR-Ni, PBT
Material housing	brass-Ni, PBT
Display flow	4-colour-illuminated LED red / yellow / green / blue
Protection [EN 60529]	IP 67
Electrical connection	2 m PVC-cable 3x0.5 mm ²

Technical Image

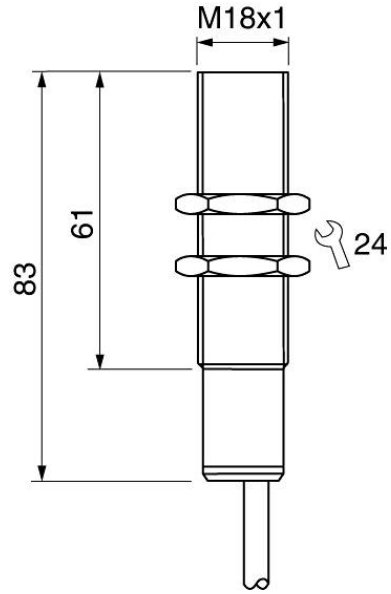

Pin Map

