

Application-specific temperature sensors |

TGM 025-03

- Switches directly if the temperature threshold is exceeded
- 230 VDC
- Compact and robust design in stainless steel housing and with G ½ thread
- Temperature thresholds in the range from 60° C ... 100° C freely selectable ex factory
- For use in fluids
- For the protection of plant components and systems against overheating



TYPE	TGM 025-03
Product ID	P71032
Thermocouple	NiCr-Ni(Typ K)
Ambient temperature	-25 ... 350 °C
Medium temperature	-50 ... 1000 °C
Compressive strength (at 25°C)	40 bar
Material sensor touched by medium	stainless steel AISI 316 Ti
Material housing	stainless steel AISI 316 Ti
Protection [EN 60529]	IP 68 / IP 69
Protection [EN 60529] housing	IP 60
Electrical connection	2 m connection cable with stainless steel braided hose

Technical Image

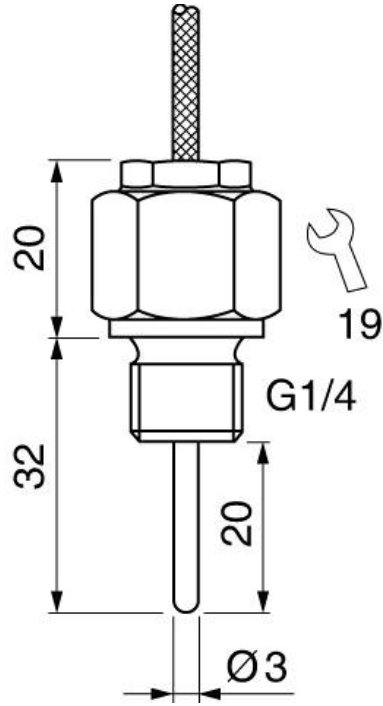

Pin Map

