

Sensors without integrated amplifier | STA 421 S-B3

- G1/2 screw-in sensor for flow monitoring in liquid media
- Corrosion-proof titanium housing with metal-ceramic coating
- Immersion depth 34 mm
- M12 plug system
- Installation in T-piece connector or welding sleeve
- Needs amplifier with analogue or switching output



G1/2 titanium/metal ceramic coating - sensor length 34 mm - M12 connector

TYPE	STA 421 S-B3
Product ID	P10622
Medium	Water, oil
Detection range water	1 ... 150 cm/s
Detection range Oil	3 ... 300 cm/s
Process connection	G1/2
Sensor length L	34 mm
Ambient temperature	-20 ... 80 °C
Medium temperature	-20 ... 80 °C
Temperature gradient fluids	250 K/min
Start-up time typ.	8 s (2 ... 15 s)
Reaction time typ.	2 s (1 ... 13 s)
Compressive strength	100 bar
Material sensor touched by medium	metall-ceramic coating, titan
Material housing	metal-ceramic coating, titan
Protection [EN 60529]	IP 67
Electrical connection	M12 connector
Accessories (in scope of delivery)	2 x gasket G1/2 AFM 34

Associated amplifiers

SKM 420, SKM 522, SKZ 400

Note

temperature range 10 °C...120 °C on request

Technical Image

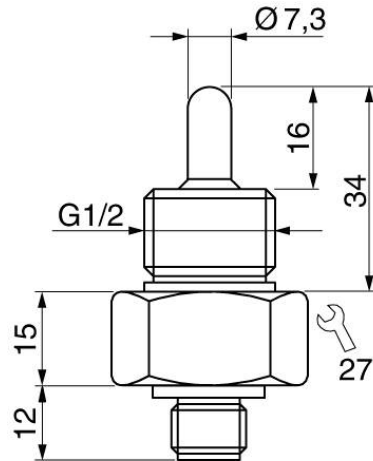

Pin Map

