

## Sensors for explosive areas without amplifier for liquid media | STS 102 K

- G1/4 screw-in sensor for flow monitoring in liquid media
- ATEX approval for operation in Zone 0 and Zone 20
- ATEX approval for operation in Ex separation wall Zone 0/1
- Medium temperature up to 85 °C
- Corrosion-proof stainless steel housing AISI 316 Ti
- Immersion depth 31 mm
- 2 m fixed cable PUR
- Installation in T-piece or welding sleeve
- Needs ATEX certified amplifier with analogue or switching output
- Observe special conditions for safe use

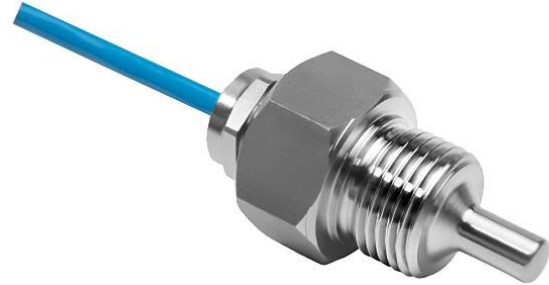

### G1/2 - sensor length 31 mm - Ex-Zone 0/20 - PUR-cable

<b>TYPE</b>	STS 102 K
<b>Product ID</b>	P11141
<b>Medium</b>	Water, oil
<b>Detection range water</b>	1 ... 100 cm/s
<b>Detection range Oil</b>	3 ... 200 cm/s
<b>Process connection</b>	G1/2
<b>Sensor length L</b>	31 mm
<b>Output</b>	output with separate Amplifier
<b>Ex area of use</b>	installation in partition wall Zone 0/1, Zone 0, Zone 20
<b>ATEX Certificate</b>	TÜV 98 ATEX 1298 X
<b>Marking gas Ex for partition wall mounting</b>	Ex II 1/2 G Ex ia IIC T6...T3 Ga/Gb
<b>ATEX marking gas</b>	Ex II 1 G Ex ia IIC T6...T3 Ga
<b>ATEX Marking dust</b>	Ex II 1 D Ex ia IIIC T125°C Da
<b>Maximum values</b>	Ui = 13.65 V / Ii = 200 mA / Pi = 0.69 W / Ci = 0.45 nF / Li = 1.80 µH
<b>Temperature range in T6</b>	-20 ... 40 °C

<b>Temperature range in T5</b>	-20 ... 55 °C
<b>Temperature range in T4</b>	-20 ... 85 °C
<b>Temperature range in T3</b>	-20 ... 85 °C
<b>Temperature range dust-Ex</b>	-20 ... 85 °C
<b>Start-up time typ.</b>	8 s (2 ... 18 s)
<b>Reaction time typ.</b>	2 s (1 ... 13 s)
<b>Compressive strength</b>	60 bar
<b>Material sensor touched by medium</b>	stainless steel AISI 316 Ti
<b>Material housing</b>	stainless steel AISI 316 Ti, brass
<b>Protection [EN 60529]</b>	IP 67
<b>Electrical connection</b>	2 m PUR-cable, 4x0.25 mm <sup>2</sup>
<b>Accessories (in scope of delivery)</b>	2 x gasket G1/2 AFM 34
<b>Associated amplifiers</b>	SZAb 400 EX-GR, SZAb 400 EX-WR115, SZAb 400 EX-WR230, SZAb 400 EX-GA
<b>Note</b>	probe with longer cable available on request

Technical Image

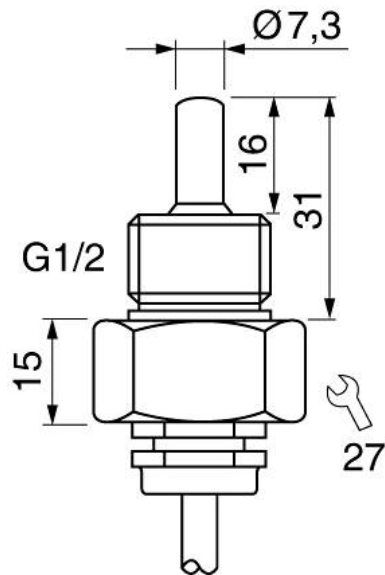

Pin Map

