

Sensors for explosive areas without amplifier for liquid media | STS 110 K

- G1/2 screw-in sensor for flow monitoring in liquid media
- ATEX approval for operation in Zone 0 and Zone 20
- ATEX approval for operation in Ex separation wall Zone 0/1
- Medium temperature up to 85 °C
- Corrosion-proof stainless steel housing AISI 316 Ti
- Immersion depth 48 mm - thread length 20 mm
- 2 m fixed cable PUR
- Installation in T-piece or welding sleeve
- Needs ATEX certified amplifier with analogue or switching output
- Observe special conditions for safe use

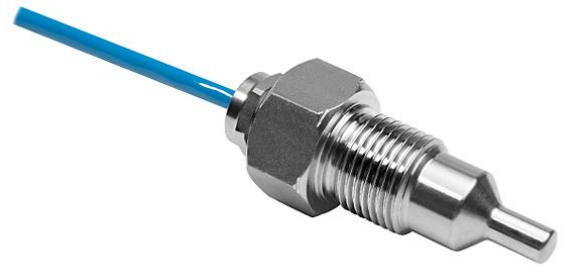

G1/2 - sensor length 48 mm - Ex-Zone 0/20 - PUR-cable

TYPE	STS 110 K
Product ID	P11186
Medium	Water, oil
Detection range water	1 ... 100 cm/s
Detection range Oil	3 ... 200 cm/s
Process connection	G1/2
Sensor length L	48 mm
Output	output with separate Amplifier
Ex area of use	installation in partition wall Zone 0/1, Zone 0, Zone 20
ATEX Certificate	TÜV 98 ATEX 1298 X
Marking gas Ex for partition wall mounting	Ex II 1/2 G Ex ia IIC T6...T3 Ga/Gb
ATEX marking gas	Ex II 1 G Ex ia IIC T6...T3 Ga
ATEX Marking dust	Ex II 1 D Ex ia IIIC T125°C Da
Maximum values	U _i = 13.65 V / I _i = 200 mA / P _i = 0.69 W / C _i = 0.45 nF / L _i = 1.80 µH
Temperature range in T6	-20 ... 40 °C
Temperature range in T5	-20 ... 55 °C
Temperature range in T4	-20 ... 85 °C

Temperature range in T3	-20 ... 85 °C
Temperature range dust-Ex	-20 ... 85 °C
Start-up time typ.	8 s (2 ... 18 s)
Reaction time typ.	2 s (1 ... 13 s)
Compressive strength	60 bar
Material sensor touched by medium	stainless steel AISI 316 Ti
Material housing	stainless steel AISI 316 Ti, brass
Protection [EN 60529]	IP 67
Electrical connection	2 m PUR-cable, 4x0.25 mm ²
Accessories (in scope of delivery)	2 x gasket G1/2 AFM 34
Associated amplifiers	SZAb 400 EX-GR, SZAb 400 EX-WR115, SZAb 400 EX-WR230, SZAb 400 EX-GA
Note	probe with longer cable available on request

Technical Image

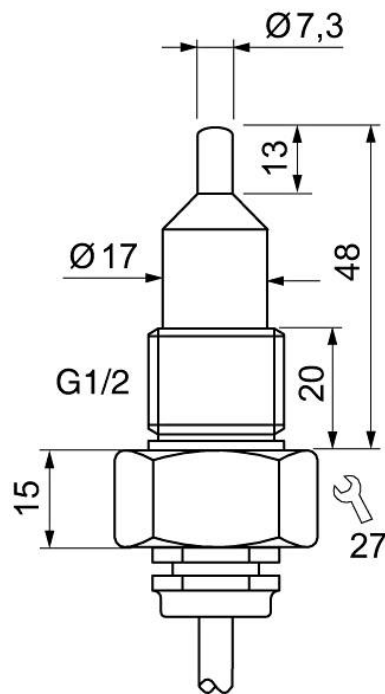

Pin Map

